

XU-4 Pump Data

Net Weight	272kg (600lbs)
Shipping Weights	297kg (655lbs)
Impeller Diameter	279.4mm (11")
RPM	From 850 RPM to 2150 RPM
Max Solids	28.57mm (1 1/8")

Self-Priming Head

850 RPM	2.4m (8ft)	-	1150 RPM	3.0m (10ft)
1450 RPM	3.6m (12ft)	-	1750 RPM	3.9m (13ft)
1950 RPM	4.5m (15ft)		2150 RPM	5.2m (17ft)

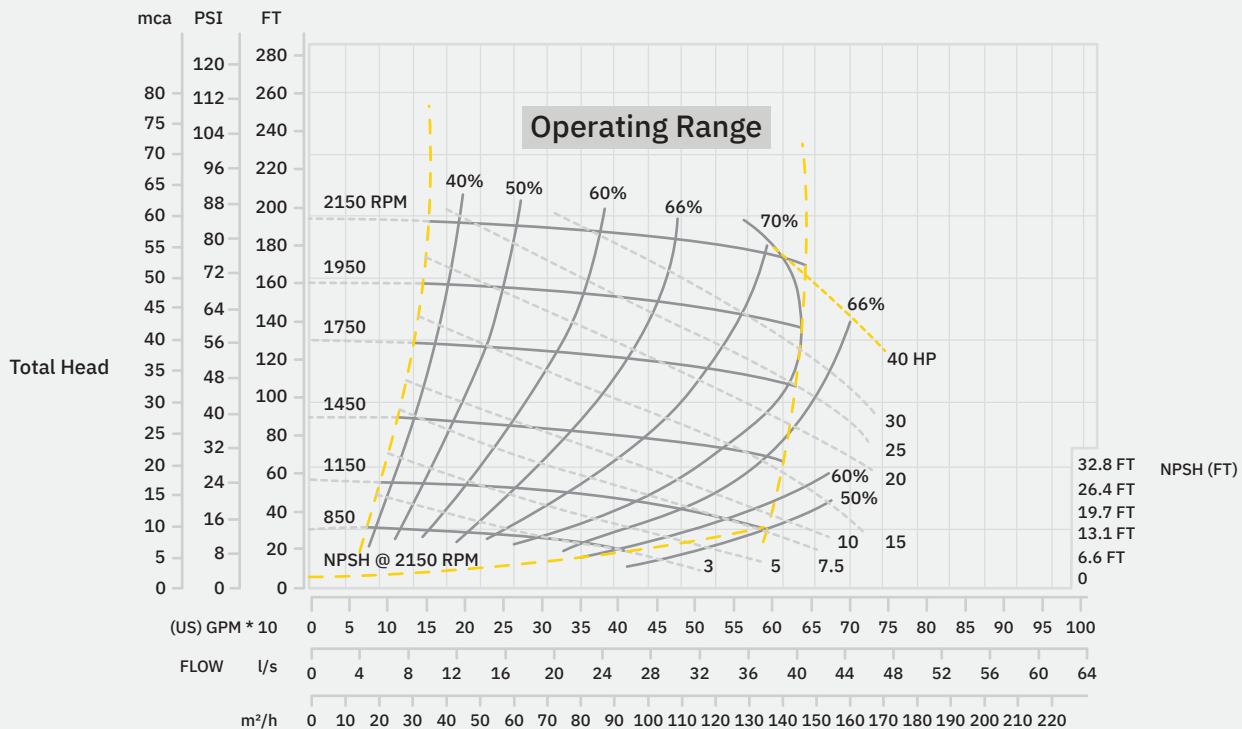

Performance Curve: 4" X 4"

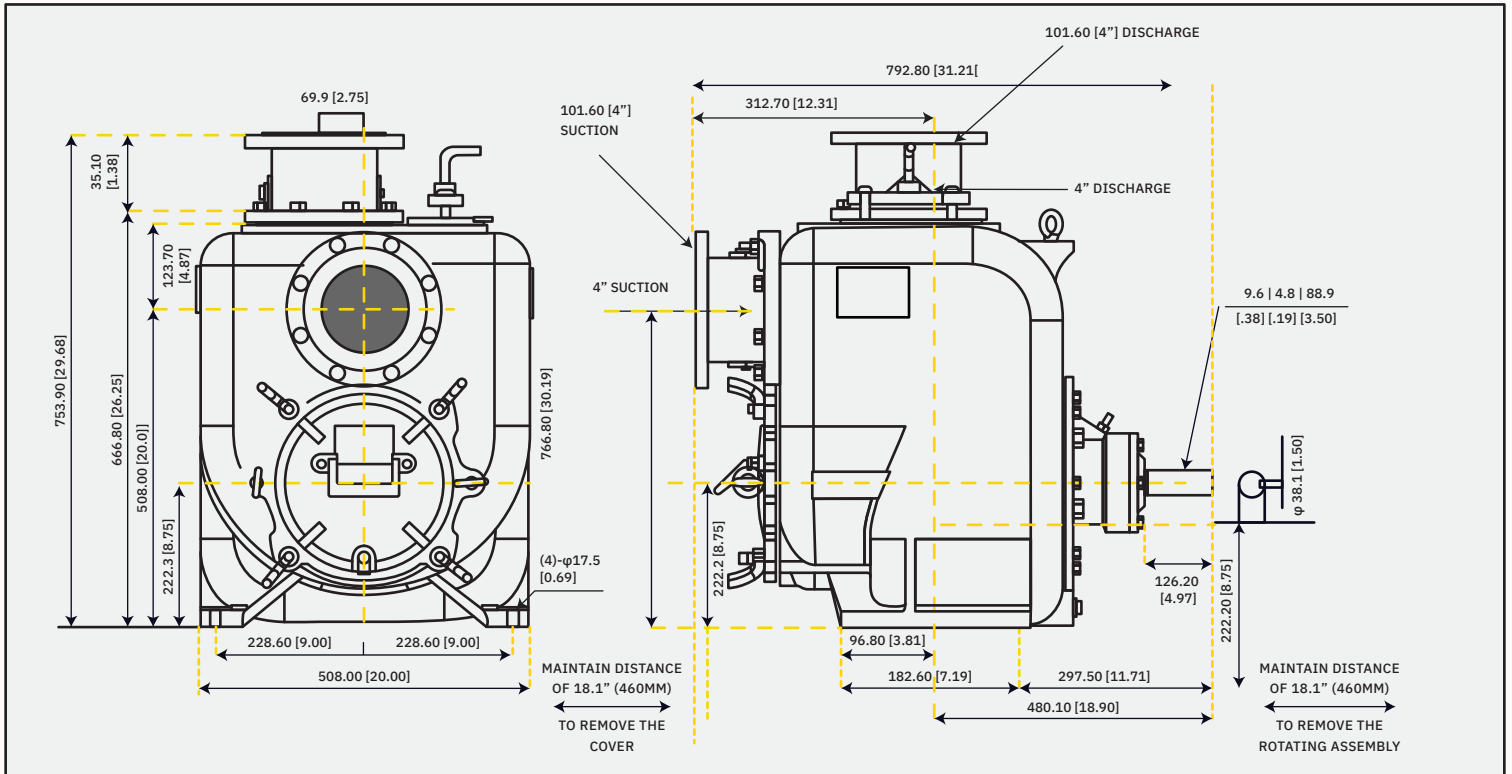

Component	STD	CI / 316SS	CI / CD4MCU	CI / ADI	CI / HCI	ADI	316SS	CD4MCU	
Casting	-	-	A48CL30	-	-	ADI	316SS	CD4MCU	
Impeller	A60-40-18	316SS	CD4MCU	ADI	HCI	ADI	316SS	CD4MCU	
Wear Plate	A48CL30	316SS	CD4MCU	ADI	HCI	ADI	316SS	CD4MCU	
Cover Plate	A48CL30					ADI	316SS	CD4MCU	
Bearing Housing	A48CL30					ADI	316SS	CD4MCU	
Seal Plate	A48CL30	316SS	CD4MCU	ADI	HCI	ADI	316SS	CD4MCU	
Flap Valve	Neoprene					Viton			
Impeller Shaft	ANSI4140HT				ANSI17-4PH				
Seal Sleeve	ANSI4140HT				ANSI17-4PH				
Flanges	A48CL30					ADI	316SS	CD4MCU	
O Rings			Buna			-	Viton	-	
Mechanical Seal		316SS, Buna, Tungst/Titanium Carbide				316SS, Viton, Tungst/Titanium Carbide			

Materials of Construction