

XU-3 Pump Data

Net Weight	214kg (472lbs)
Shipping Weights	225kg (497lbs)
Impeller Diameter	297.4mm (11")
RPM	From 850 RPM to 2150 RPM
Max Solids	20.63mm (1 and 3/16")

Self-Priming Head

850 RPM	2.3m (7ft)	-	1150 RPM	2.9m (9ft)
1450 RPM	4.5m (15ft)	-	1750 RPM	7.6m (25ft)
1950 RPM	7.6m (25ft)	-	2150 RPM	7.6m (25ft)

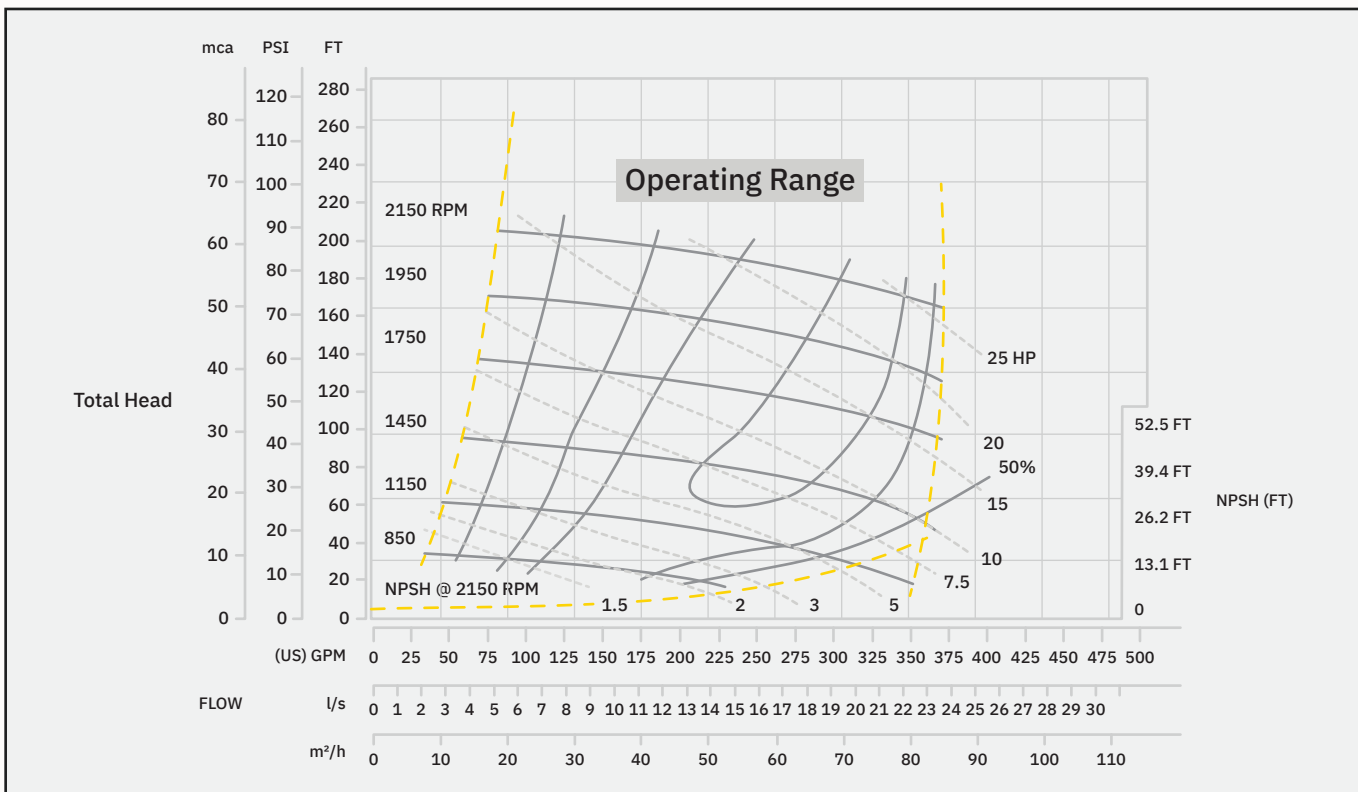

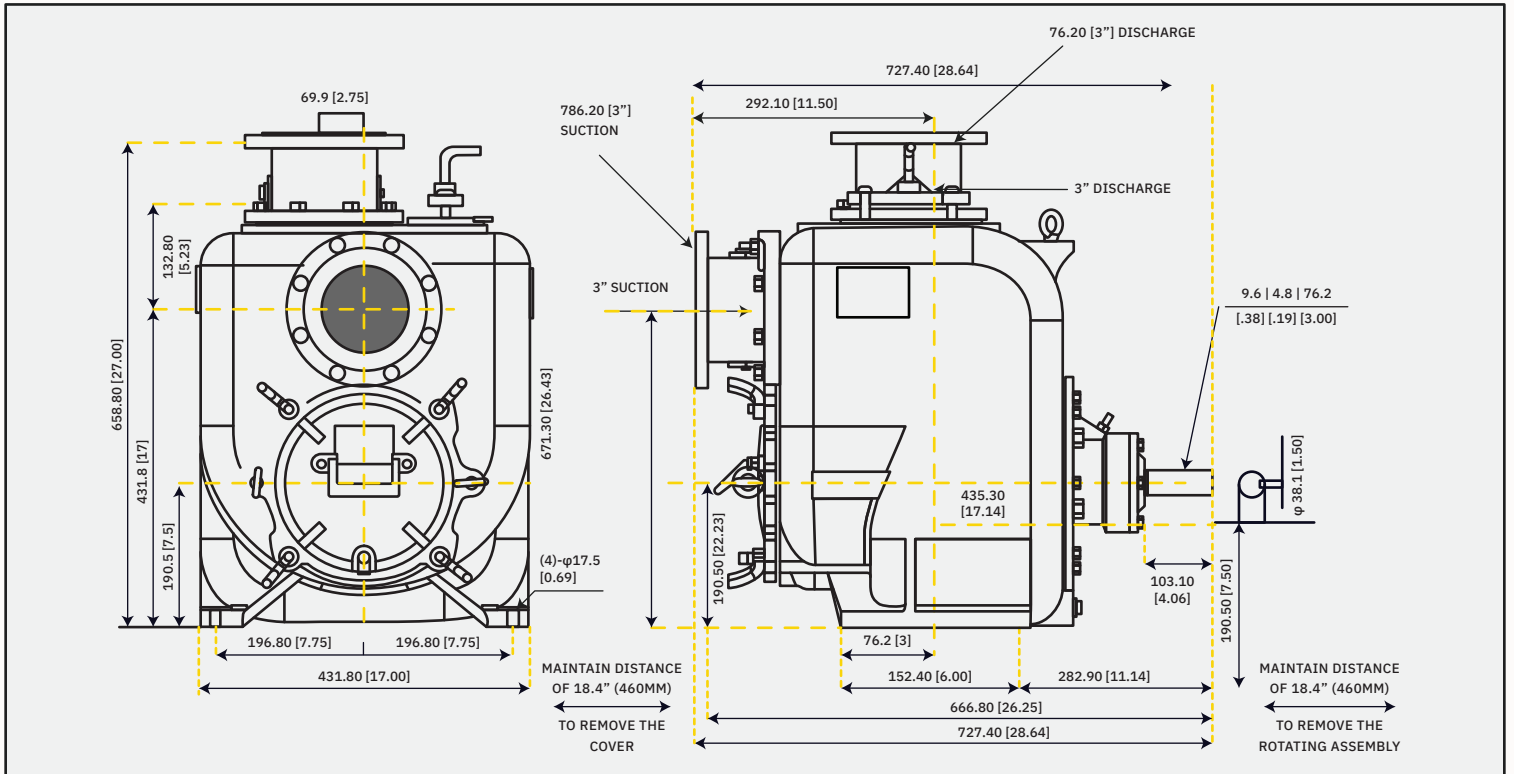

Component	STD	CI / 316SS	CI / CD4MCU	CI / ADI	CI / HCI	ADI	316SS	CD4MCU
Casting	-	-	A48CL30	-	-	ADI	316SS	CD4MCU
Impeller	A60-40-18	316SS	CD4MCU	ADI	HCI	ADI	316SS	CD4MCU
Wear Plate	A48CL30	316SS	CD4MCU	ADI	HCI	ADI	316SS	CD4MCU
Cover Plate	A48CL30					ADI	316SS	CD4MCU
Bearing Housing	A48CL30					ADI	316SS	CD4MCU
Seal Plate	A48CL30	316SS	CD4MCU	ADI	HCI	ADI	316SS	CD4MCU
Flap Valve	Neoprene					Viton		
Impeller Shaft	ANSI4140HT					ANSI17-4PH		
Seal Sleeve	ANSI4140HT					ANSI17-4PH		
Flanges	A48CL30					ADI	316SS	CD4MCU
O Rings			Buna			-	Viton	-
Mechanical Seal		316SS, Buna, Tungst/Titanium Carbide				316SS, Viton, Tungst/Titanium Carbide		

Materials of Construction