



PL-10 Pump Data

Net Weight	635kg (1400lbs)
Shipping Weights	662.7kg (1461lbs)
Impeller Diameter	374.64mm (14 3/4")
RPM	From 650 RPM to 1450 RPM
Max Solids	76.2mm (3")

Self-Priming Head

650 RPM 2.1m (7ft)	-	750 RPM 3.4m (11ft)	1250 RPM 5.8m (19ft)	-	1350 RPM 6.7m (22ft)
850 RPM 4.3m (14ft)	-	950 RPM 5.2m (17ft)	1450 RPM 6.7m (22ft)		
1050 RPM 5.5m (18ft)	-	1150 RPM 5.5m (18ft)			

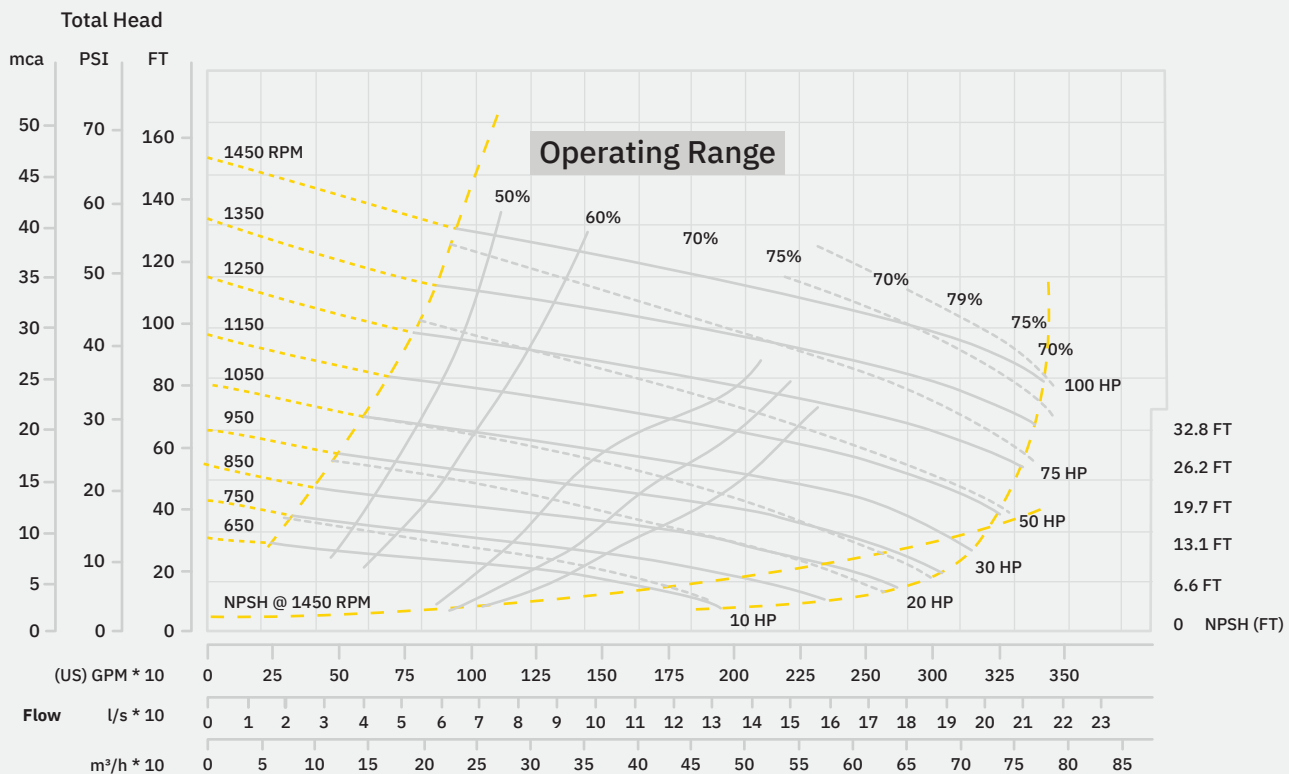

Performance Curve: 10" x 10"

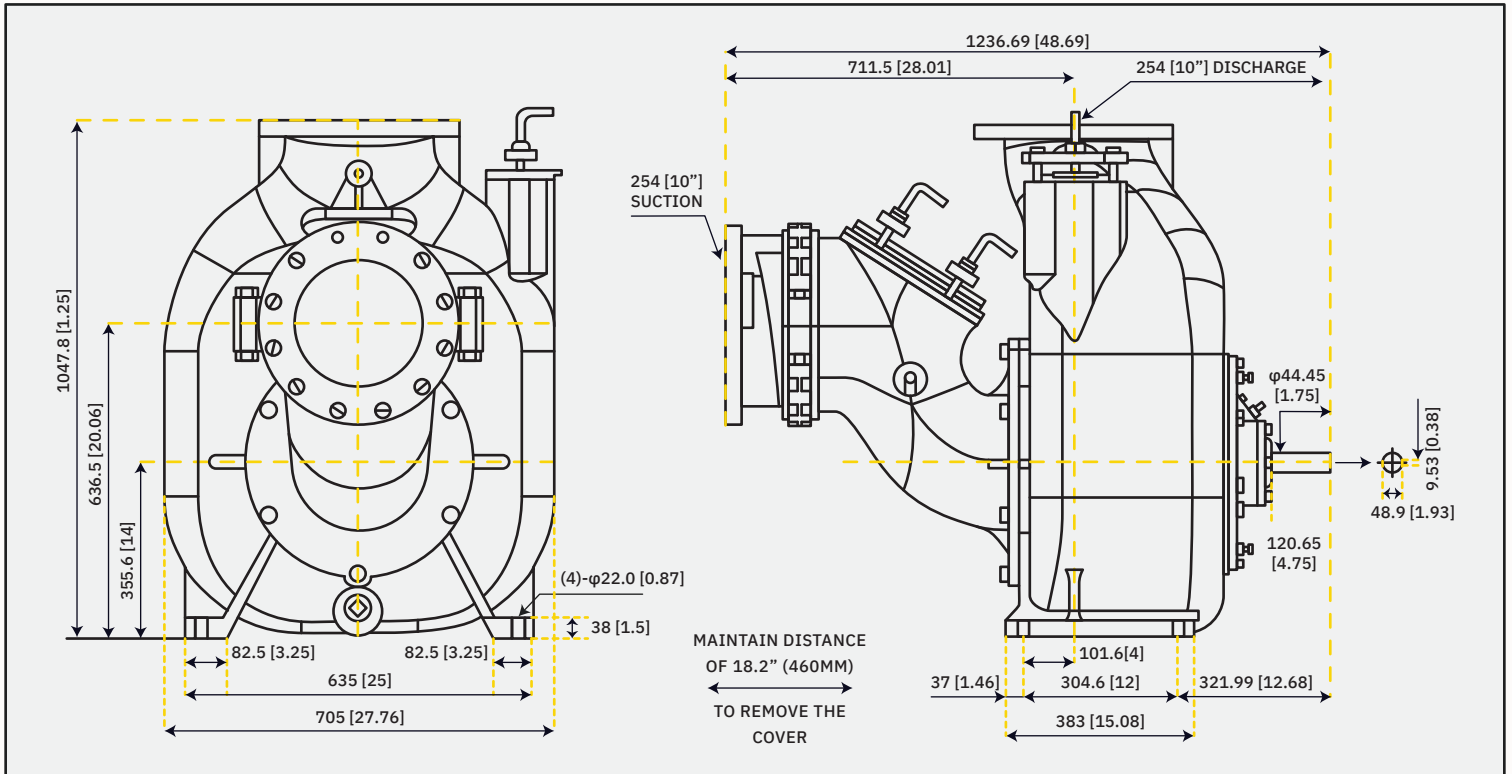

Component	STD	CI / 316SS	CI / CD4MCU	CI / ADI	CI / HCI	ADI	316SS	CD4MCU
Casting		A48CL30				ADI	316SS	CD4MCU
Impeller	A60-40-18	316SS	CD4MCU	ADI	HCI	ADI	316SS	CD4MCU
Wear Plate	A48CL30	316SS	CD4MCU	ADI	HCI	ADI	316SS	CD4MCU
Cover Plate		A48CL30				ADI	316SS	CD4MCU
Bearing Housing		A48CL30				ADI	316SS	CD4MCU
Seal Plate	A48CL30	316SS	CD4MCU	ADI	HCI	ADI	316SS	CD4MCU
Flap Valve		Neoprene				Viton		
Impeller Shaft	ANSI4140HT	ANSI17-4PH						
Seal Sleeve	ANSI4140HT	ANSI17-4PH						
Flanges		A48CL30				ADI	316SS	CD4MCU
O Rings		Buna				Viton		
Mechanical Seal		316SS, Buna, Tungs/Titanium Carbide				316SS, Viton, Tungs/Titanium Carbide		

Materials of Construction