

PH-6 Pump Data

Net Weight	413kg (910lbs)
Shipping Weights	437kg (965lbs)
Impeller Diameter	317.5mm (12 1/2")
RPM	From 850 RPM to 1950 RPM
Max Solids	31.75mm (1 1/4")

Self-Priming Head

850 RPM	2.4m (8ft)	-	1150 RPM	3.0m (10ft)
1450 RPM	4.2m (10ft)	-	1750 RPM	4.5m (15ft)
1950 RPM	4.5m (15ft)			

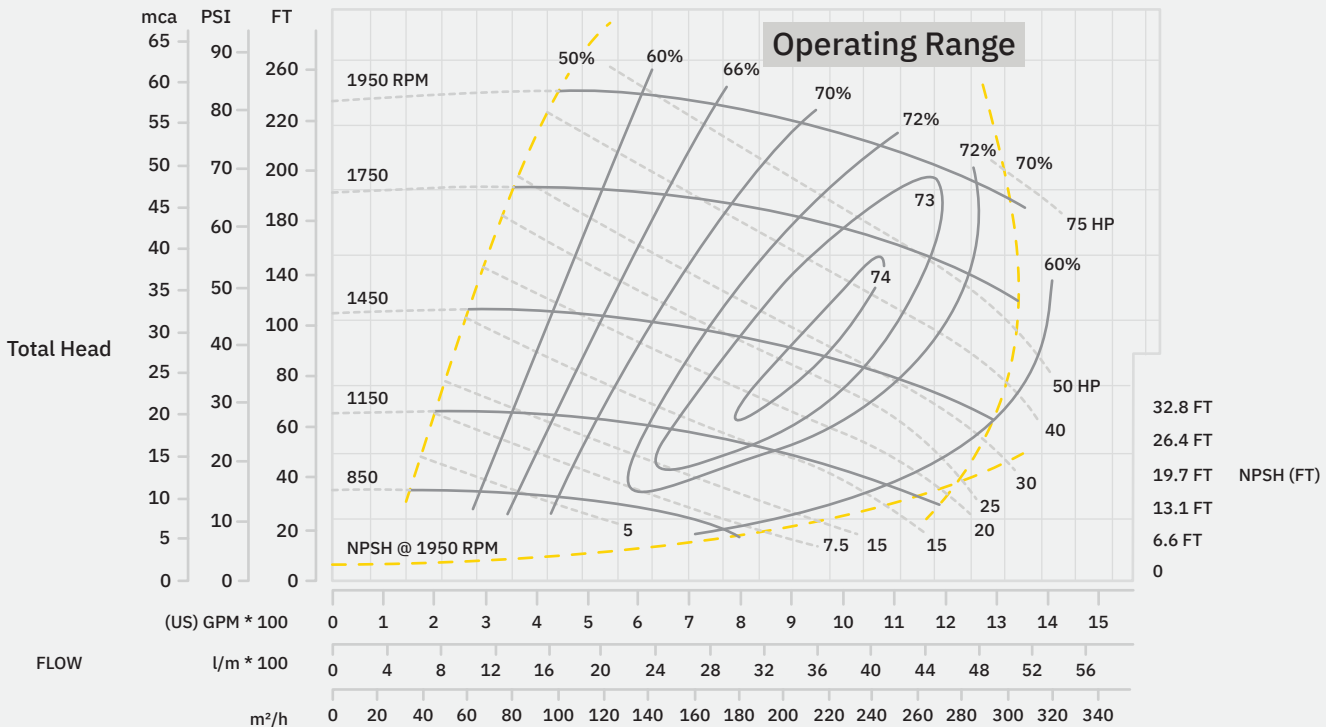

Performance Curve: 6" X 6"

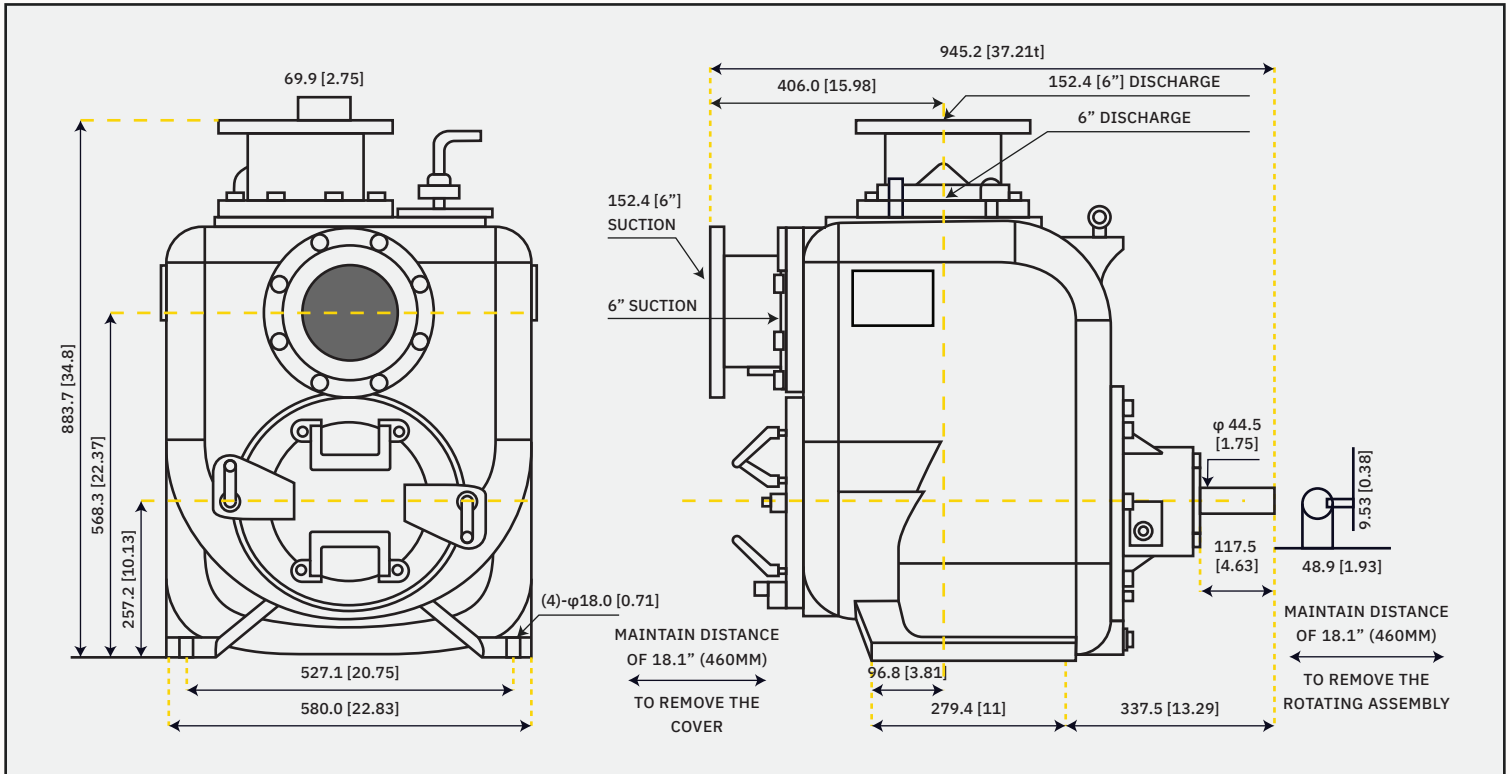

Component	STD	CI / 316SS	CI / CD4MCU	CI / ADI	CI / HCI	ADI	316SS	CD4MCU
Casting	-	-	A48CL30	-	-	ADI	316SS	CD4MCU
Impeller	A60-40-18	316SS	CD4MCU	ADI	HCI	ADI	316SS	CD4MCU
Wear Plate	A48CL30	316SS	CD4MCU	ADI	HCI	ADI	316SS	CD4MCU
Cover Plate			A48CL30			ADI	316SS	CD4MCU
Bearing Housing			A48CL30			ADI	316SS	CD4MCU
Seal Plate	A48CL30	316SS	CD4MCU	ADI	HCI	ADI	316SS	CD4MCU
Flap Valve	Neoprene					Viton		
Impeller Shaft	ANSI1410HT				ANSI17-4PH			
Seal Sleeve	ANSI1410HT				ANSI17-4PH			
Flanges			A48CL30			ADI	316SS	CD4MCU
O Rings			Buna				Viton	
Mechanical Seal			316SS, Buna, Tungst/Titanium Carbide				316SS, Viton, Tungst/Titanium Carbide	

Materials of Construction