



### DATA SHEET

NET WEIGHT 413kg (910lbs)

SHIPPING WEIGHTS 437kg (965lbs)

IMPELLER DIA. 317.5mm (12.1/2")

R.P.M. FROM 850 rpm TO 1950rpm

MAX. SOLIDS 31.75mm(1.1/4")

### SELF-PRIMING HEAD

850 RPM 2.4m (8ft) - 1150 rpm 3.0m (10ft)

1450 RPM 4.2m (10ft) - 1750 rpm 4.5m (15ft)

1950 RPM 4.5m (15ft)

BEFORE USING THIS TABLE,CHECK THE NPSH.

### PERFORMANCE CURVE 6"X6"

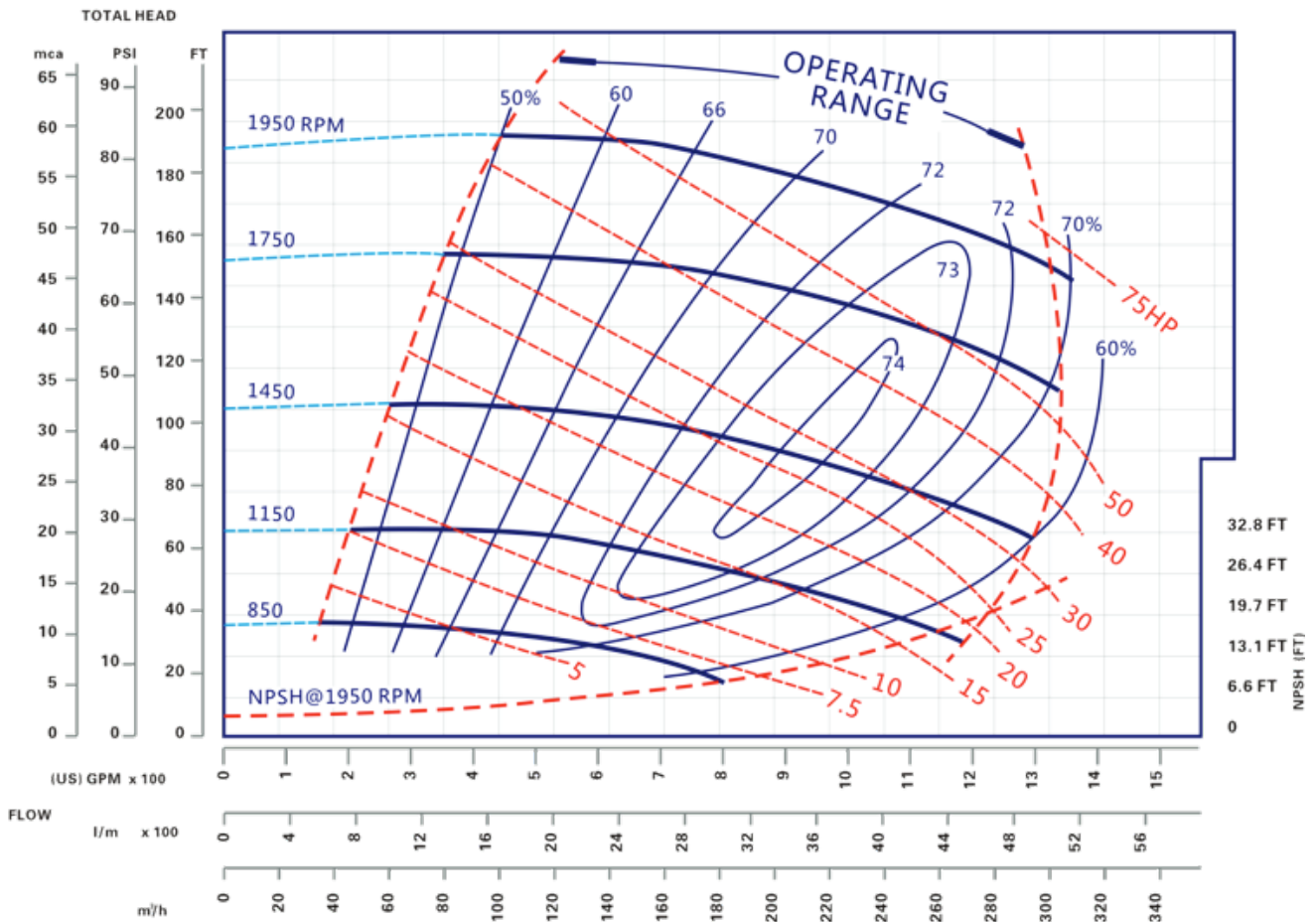

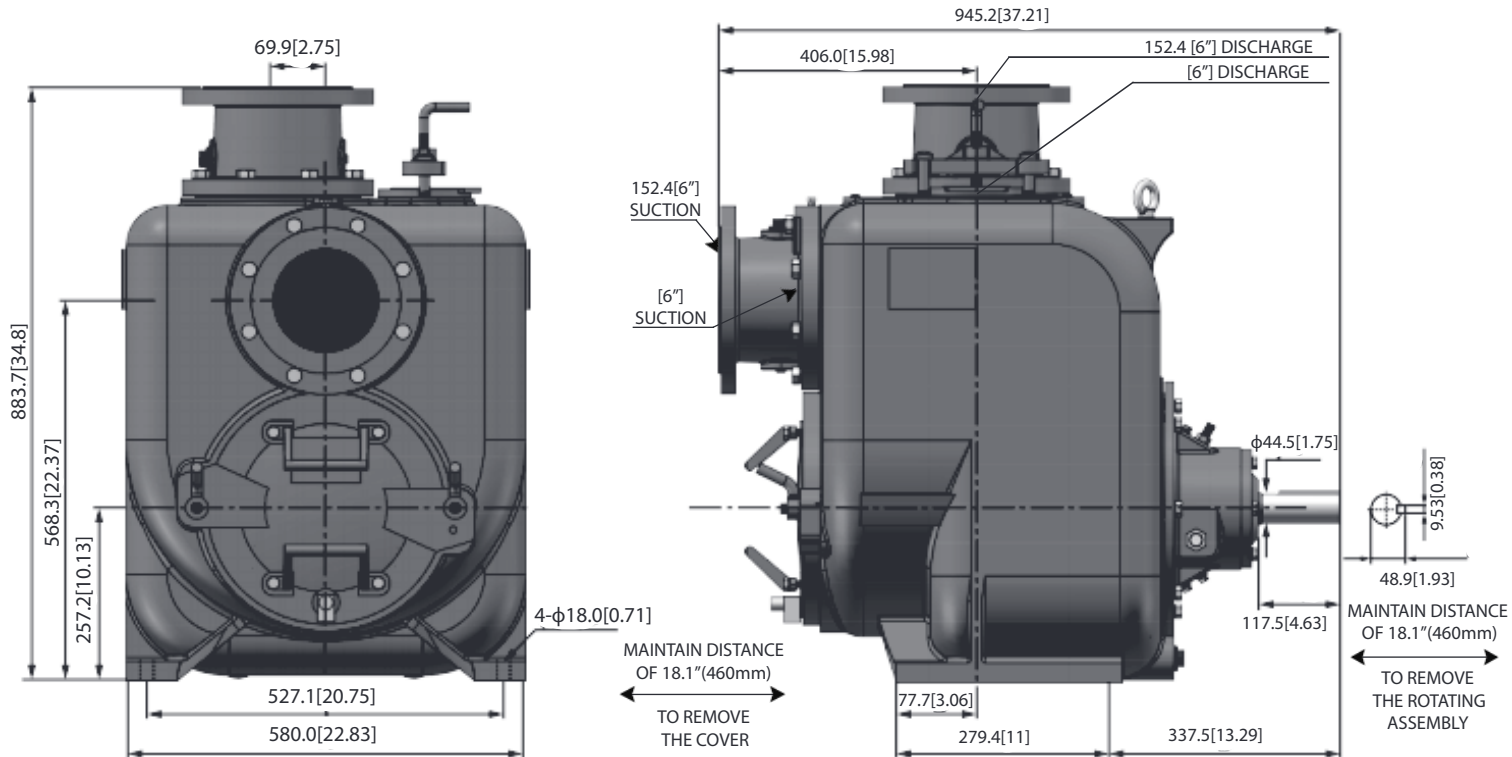

COMPONENT	MATERIALS OF CONSTRUCTION							
	STD	CI/316SS	CI/CD4MCU	CI/ADI	CI/HCI	ADI	316SS	CD4MCU
Casing			A48CL30			ADI	316SS	CD4MCU
Impeller	A60-40-18	316SS	CD4MCU	ADI	HCI	ADI	316SS	CD4MCU
Wear Plate	A48CL30	316SS	CD4MCU	ADI	HCI	ADI	316SS	CD4MCU
Cover Plate			A48CL30			ADI	316SS	CD4MCU
Bearing Housing			A48CL30			ADI	316SS	CD4MCU
Seal Plate	A48CL30	316SS	CD4MCU	ADI	HCI	ADI	316SS	CD4MCU
Flap Valve			NEOPRENE				VITON	
Impeller Shaft	ANSI4140HT			ANSI117-4PH				
Seal Sleeve	ANSI4140HT			ANSI117-4PH				
Flanges			A48CL30			ADI	316SS	CD4MCU
O'rings			BUNA				VITON	
Mechanical Seal		316SS,BUNA,TUNGS/TITANIUM CARBIDE				316SS,VITON,TUNGS/TITANIUM CARBIDE		