

DATA SHEET

NET WEIGHT 214kg (472lbs)
 SHIPPING WEIGHTS 225kg (497lbs)
 IMPELLER DIA. 297.4mm (11")
 R.P.M. FROM 850 rpm TO 2150rpm
 MAX. SOLIDS 20.63mm(1 3/16")

SELF-PRIMING HEAD

850 RPM 2.3m (7ft) - 1150 rpm 2.9m (9ft)
 1450 RPM 4.5m (15ft) - 1750 rpm 7.6m (25ft)
 1950 RPM 7.6m (25ft) - 2150 rpm 7.6m (25ft)

BEFORE USING THIS TABLE,CHECK THE NPSH.

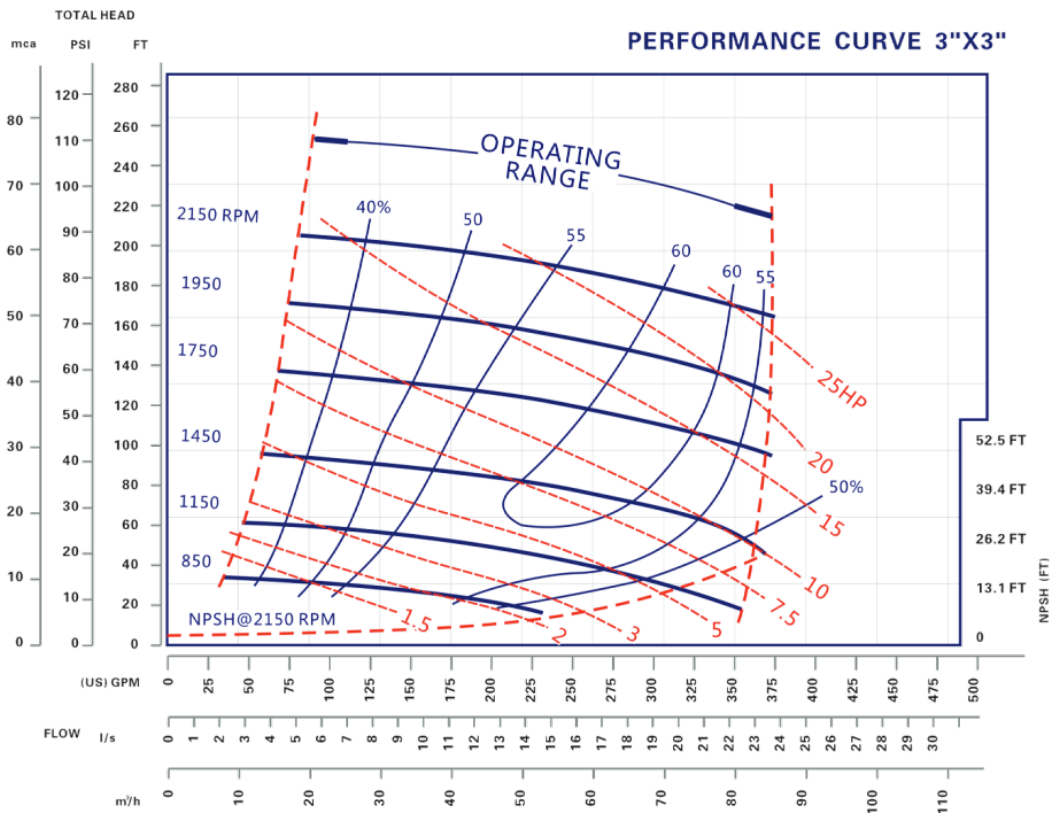

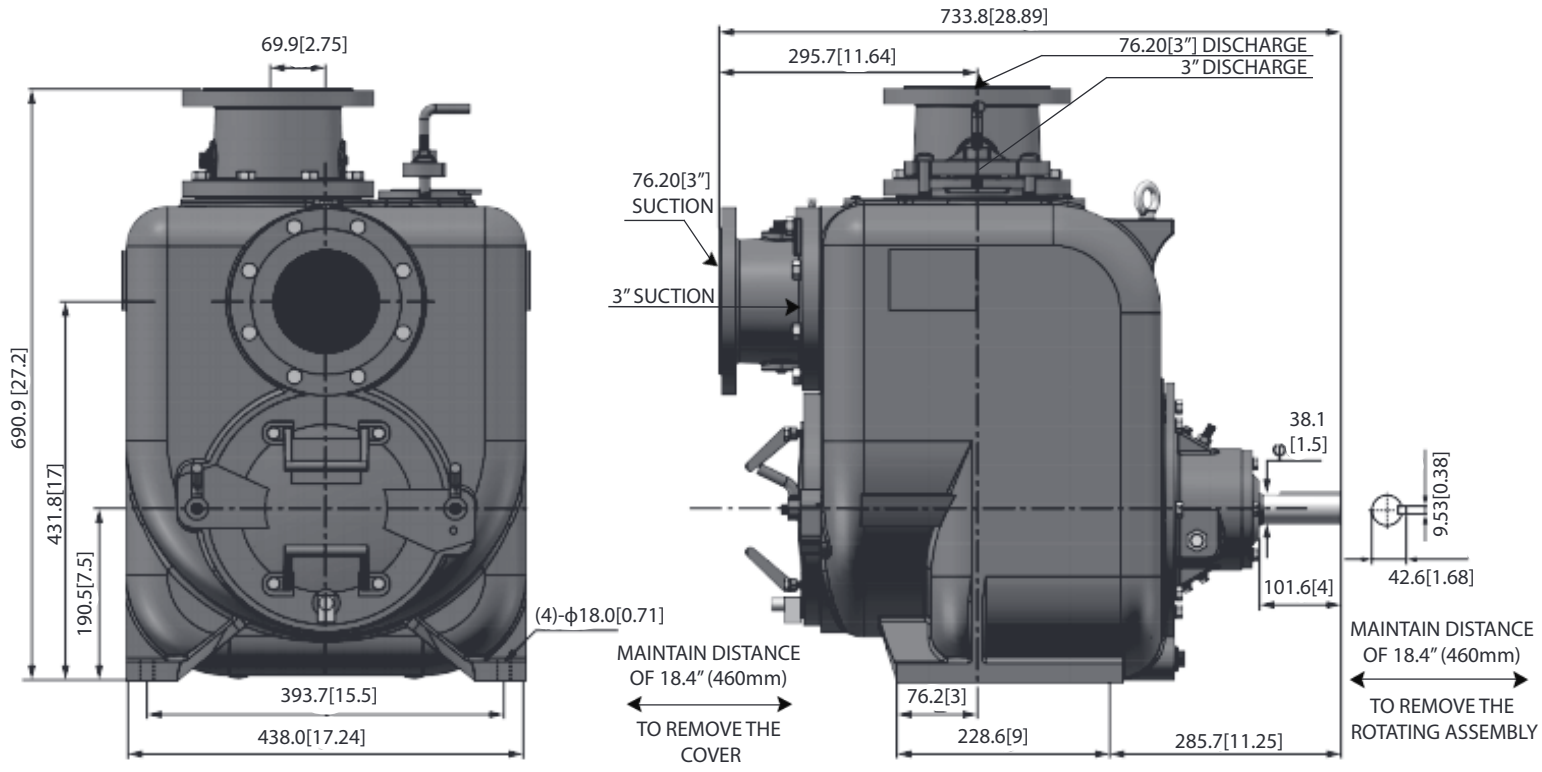

COMPONENT	MATERIALS OF CONSTRUCTION							
	STD	CI/316SS	CI/CD4MCU	CI/ADI	CI/HCI	ADI	316SS	CD4MCU
Casing			A48CL30			ADI	316SS	CD4MCU
Impeller	A60-40-18	316SS	CD4MCU	ADI	HCI	ADI	316SS	CD4MCU
Wear Plate	A48CL30	316SS	CD4MCU	ADI	HCI	ADI	316SS	CD4MCU
Cover Plate			A48CL30			ADI	316SS	CD4MCU
Bearing Housing			A48CL30			ADI	316SS	CD4MCU
Seal Plate	A48CL30	316SS	CD4MCU	ADI	HCI	ADI	316SS	CD4MCU
Flap Valve		NEOPRENE				VITON		
Impeller Shaft	ANSI4140HT	ANSI17-4PH						
Seal Sleeve	ANSI4140HT	ANSI17-4PH						
Flanges		A48CL30				ADI	316SS	CD4MCU
O'rings		BUNA				VITON		
Mechanical Seal		316SS,BUNA,TUNGS/TITANIUM CARBIDE				316SS,VITON,TUNGS/TITANIUM CARBIDE		