

DATA SHEET	
NET WEIGHT	183kg (404lbs)
SHIPPING WEIGHTS	205kg (452lbs)
IMPELLER DIA.	222.25mm (8.3/4")
R.P.M.	FROM 650 rpm TO 2150rpm
MAX. SOLIDS	63.5mm(2.1/2")
SELF-PRIMING	
650 RPM	1.5m (5ft) - 750 rpm 1.8m (6ft)
850 RPM	2.4m (8ft) - 950 rpm 3.0m (10ft)
1050 RPM	4.0m (13ft) - 1150 rpm 4.9m (16ft)
1250 RPM	5.5m (18ft) - 1350 rpm 5.8m (19ft)
1450 RPM	6.4m (21ft) - 1550 rpm 6.4m (21ft)
1650 RPM	6.7m (22ft) - 1750 rpm 6.7m (22ft)
1850 RPM	7.6m (25ft) - 1950 rpm 7.6m (25ft)
2050 RPM	7.6m (25ft) - 2150 rpm 7.6m (25ft)
BEFORE USING THIS TABLE,CHECK THE NPSH.	

PERFORMANCE CURVE 3"X3"

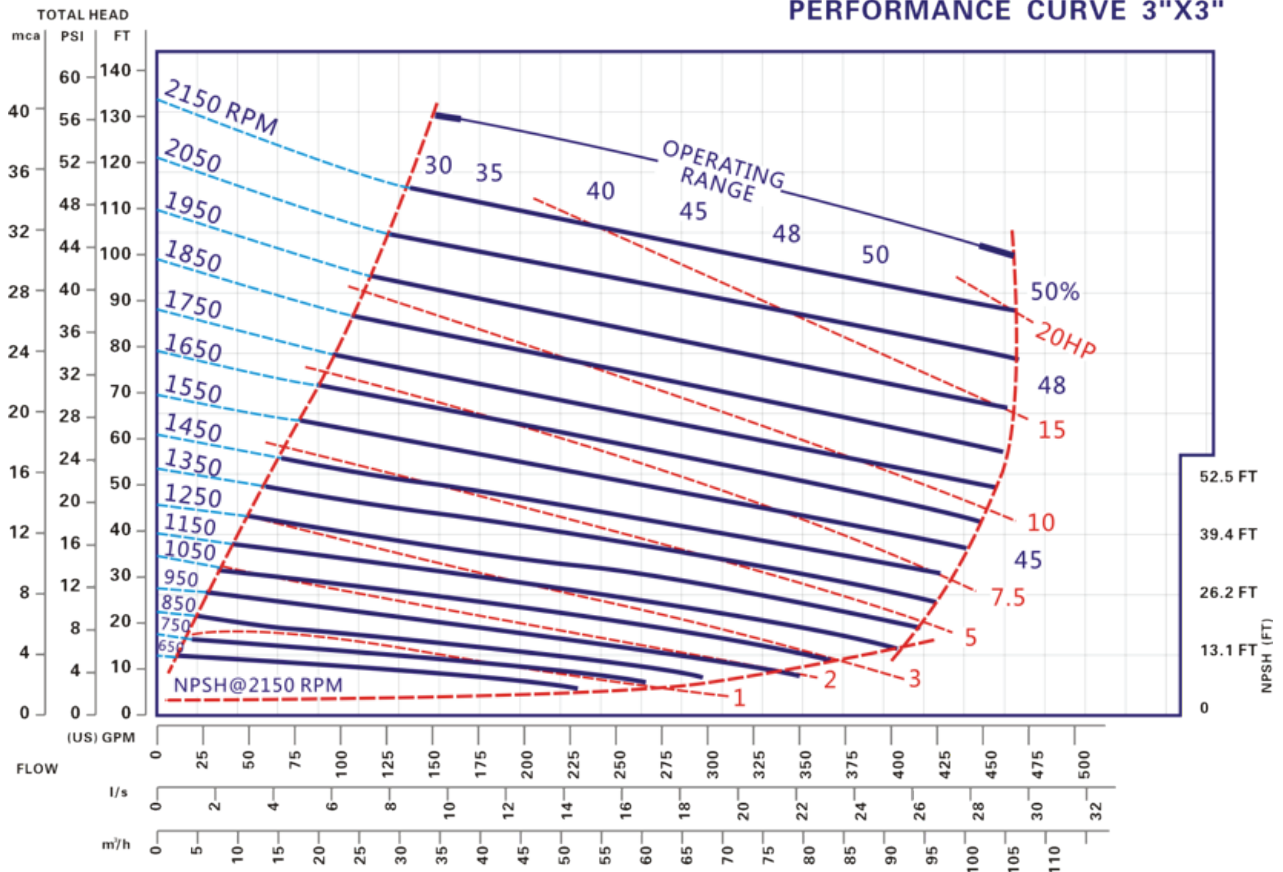

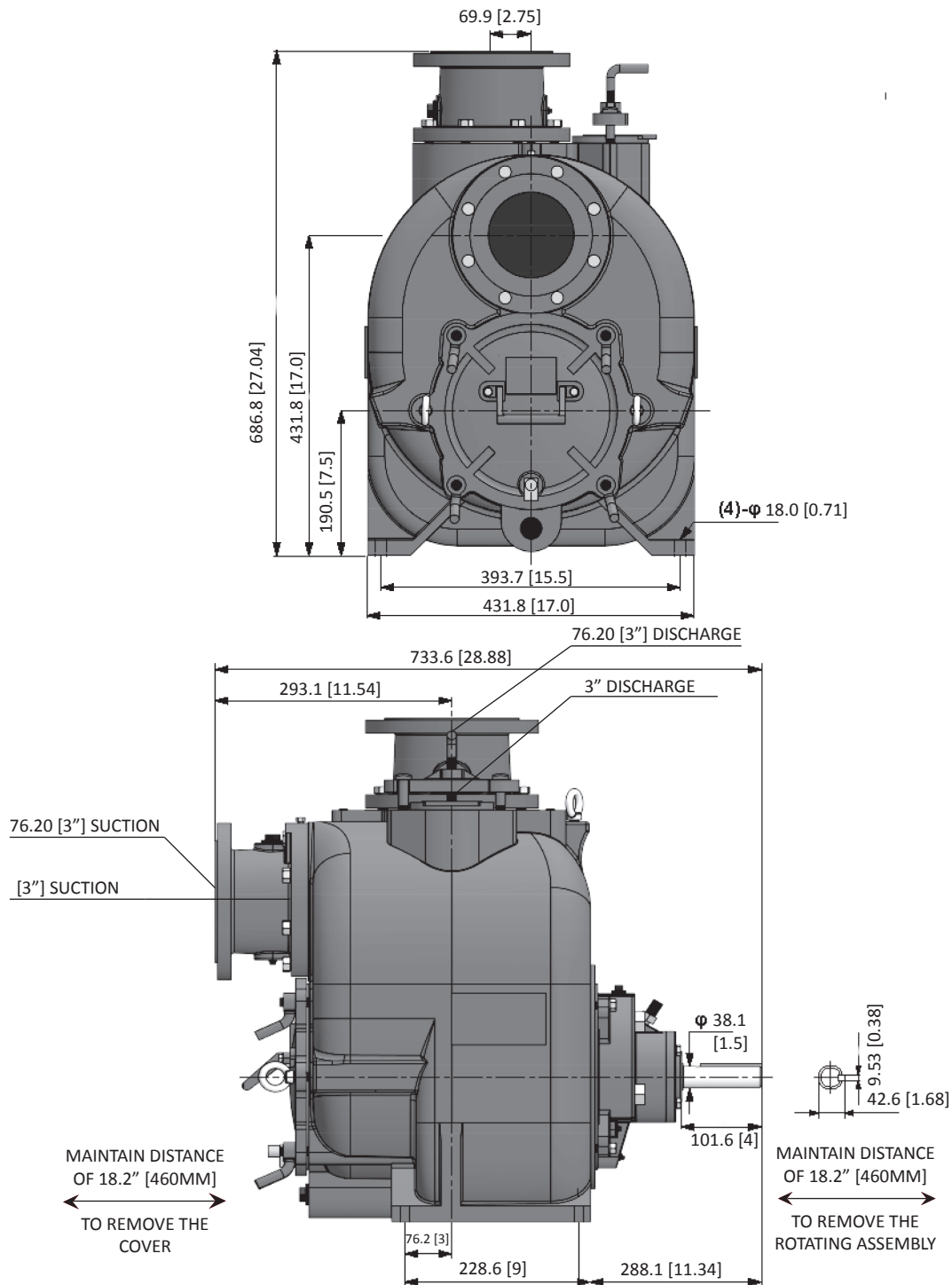

COMPONENT	MATERIALS OF CONSTRUCTION							
	STD	CI/316SS	CI/CD4MCU	CI/ADI	CI/HCI	ADI	316SS	CD4MCU
Casing			A48CL30			ADI	316SS	CD4MCU
Impeller	A60-40-18	316SS	CD4MCU	ADI	HCI	ADI	316SS	CD4MCU
Wear Plate	A48CL30	316SS	CD4MCU	ADI	HCI	ADI	316SS	CD4MCU
Cover Plate			A48CL30			ADI	316SS	CD4MCU
Bearing Housing			A48CL30			ADI	316SS	CD4MCU
Seal Plate	A48CL30	316SS	CD4MCU	ADI	HCI	ADI	316SS	CD4MCU
Flap Valve			NEOPRENE				VITON	
Impeller Shaft	ANSI4140HT			ANSI17-4PH				
Seal Sleeve	ANSI4140HT			ANSI17-4PH				
Flanges			A48CL30			ADI	316SS	CD4MCU
O-rings			BUNA				VITON	
Mechanical Seal		316SS,BUNA,TUNGS/TITANIUM CARBIDE				316SS,VITON,TUNGS/TITANIUM CARBIDE		